

4 Kutuplu 1500/1800 devir  
4 Poles 1500/1800 rpm

Kod Tanımı			Mekaniksel Değerler								Elektriksel Değerler			
Description			Mechanical Specif.								Electrical Specif.			
Kod	Tip	Govde	Statik Moment		Merkezkaç Kuvveti				Ağırlık		Motor Gücü		Akım	
			Static Moment		Centrifugal Force				Weight		Max. Power Input		Max. Input Current	
Code	Type	Size	kgmm		kg		kN		kg		(W)		(A)	
			50Hz	60Hz	50Hz	60Hz	50Hz	60Hz	50Hz	60Hz	50Hz	60Hz	400 V	460V
150-9	EMA 40-4	500	14	10	35	35	0,35	0,35	5 kg	4,5 kg	90	90	0,26	0,22
150-9	EMA 70-4	500	26	18	65	65	0,64	0,64	5 kg	4,5 kg	90	90	0,26	0,22
150-9	EMA 100-4	500	38	26	95	95	0,93	0,93	5 kg	4,5 kg	90	90	0,26	0,22
150-15	EMA 200-4	600	82	57	210	210	2,02	2,02	12 kg	11 kg	180	180	0,41	0,36
150-15	EMA 250-4	600	97	67	245	245	2,39	2,39	12,5 kg	11 kg	180	180	0,41	0,36
150-30	EMA 450-4	700	171	119	430	430	4,21	4,21	20 kg	18 kg	300	300	0,72	0,62
150-37	EMA 500-4	700	199	138	500	500	4,91	4,91	21 kg	19 kg	370	370	0,74	0,64
150-50	EMA 750-4	800	294	204	750	750	7,25	7,25	27 kg	24 kg	500	500	1,16	1,01
150-55	EMA 900-4	800	368	255	910	910	9,08	9,08	29 kg	26 kg	550	550	1,28	1,11
150-65	EMA 1150-4	800	445	309	1150	1150	10,98	10,98	38 kg	34 kg	650	650	1,45	1,26
150-95	EMA 1450-4	900	576	400	1450	1450	14,19	14,19	66 kg	59 kg	950	950	2,28	1,98
150-110	EMA 1800-4	900	736	511	1800	1800	18,15	18,15	70 kg	62 kg	1100	1100	2,46	2,14
150-130	EMA 2050-4	900	817	567	2050	2050	20,14	20,14	72 kg	64 kg	1300	1300	2,91	2,53
150-150	EMA 2350-4	900	940	653	2350	2350	23,16	23,16	78 kg	70 kg	1500	1500	3,36	2,92
150-160	EMA 2400-4	1000	953	662	2400	2400	23,50	23,50	63 kg	56 kg	1600	1600	3,84	3,33
150-190	EMA 3200-4	1000	1244	864	3150	3150	30,67	30,67	64 kg	57 kg	1900	1900	4,56	3,96
150-220	EMA 4000-4	1100	1575	1094	3950	3950	38,82	38,82	125 kg	111 kg	2200	2200	5,26	4,59
150-250	EMA 4500-4	1100	1779	1236	4470	4470	43,85	43,85	130 kg	116 kg	2500	2500	6	5,21
150-350	EMA 5000-4	1200	1984	1378	5000	5000	48,89	48,89	210 kg	178 kg	3500	3500	8,4	7,3
150-350	EMA 5700-4	1200	2259	1570	5650	5650	55,68	55,68	210 kg	178 kg	3500	3500	8,4	7,3
150-400	EMA 5750-4	1300	2284	1600	5750	5750	56,31	56,31	200 kg	195	4000	5500	497,5	9,13
150-600	EMA 6500-4	1300	2594	1802	6500	6500	63,94	63,94	220 kg	196 kg	6000	6000	11,05	11,68
150-700	EMA 8200-4	1350	3222	2239	8200	8200	79,41	79,41	225 kg	200 kg	7000	7000	14,88	12,94
150-750	EMA 8600-4	1800	3420	2370	8600	8600	84,31	84,31	460	450	7500	7500	15,07	12,45
150-8000	EMA 10200-4	1800	4052	2809	10200	10200	99,88	99,88	500	487	8000	8000	16,07	13,28
150-11000	EMA 11500-4	1800	4569	3183	11500	11500	112,62	112,97	520	506	11000	11000	21,75	18,91

Kod	Tip	Govde	Statik Moment		Merkezkaç Kuvveti				Ağırlık		Motor Gücü		Akım	
			Static Moment		Centrifugal Force				Weight		Max. Power Input		Max. Input Current	
Code	Type	Size	kgmm		kg		kN		kg		(W)		(A)	
			50Hz	60Hz	50Hz	60Hz	50Hz	60Hz	50Hz	60Hz	50Hz	60Hz	400 V	460V
150-9	EMA 40-4	500	14	10	35	35	0,35	0,35	5 kg	4,5 kg	90	90	0,26	0,22
150-9	EMA 70-4	500	26	18	65	65	0,64	0,64	5 kg	4,5 kg	90	90	0,26	0,22
150-9	EMA 100-4	500	38	26	95	95	0,93	0,93	5 kg	4,5 kg	90	90	0,26	0,22
150-15	EMA 200-4	600	82	57	210	210	2,02	2,02	12 kg	11 kg	180	180	0,41	0,36
150-15	EMA 250-4	600	97	67	245	245	2,39	2,39	12,5 kg	11 kg	180	180	0,41	0,36
150-30	EMA 450-4	700	171	119	430	430	4,21	4,21	20 kg	18 kg	300	300	0,72	0,62
150-37	EMA 500-4	700	199	138	500	500	4,91	4,91	21 kg	19 kg	370	370	0,74	0,64

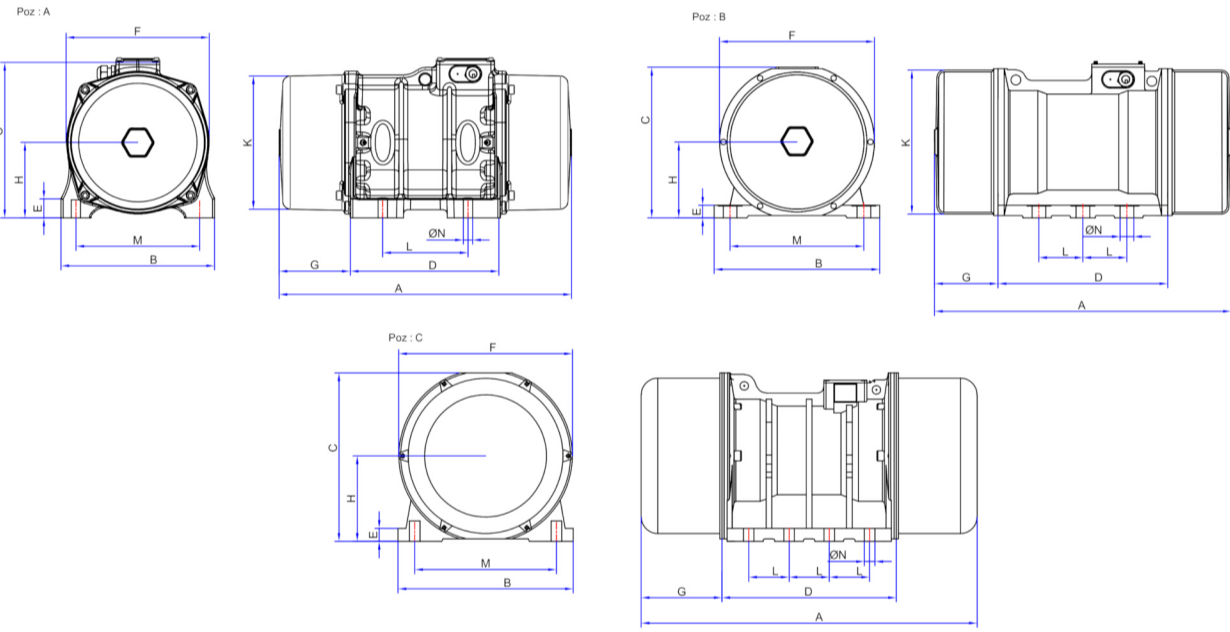

Kod Tanımı		Ölçüler													Kablo Girişi
Description		Dimensional Specif.													
Tip	Poz	A	B	C	D	E	F	G	H	K	L	M	N	P	Cable entry Thread
EMA 40-4	A	260	125	160	120	21	117	65	61	102	61-75	106	9	4	PG-11
EMA 70-4	A	260	125	160	120	21	117	65	61	102	61-75	106	9	4	PG-11
EMA 100-4	A	260	125	160	120	21	117	65	61	102	61-75	106	9	4	PG-11
EMA 200-4	A	300	154	180	142	25	144	76	75	129	90	125	13	4	PG-11
EMA 250-4	A	300	154	180	142	25	144	76	75	129	90	125	13	4	PG-11
EMA 450-4	A	360	170	198	150	27	156	102	81	146	105	140	13	4	PG-11
EMA 500-4	A	360	170	198	150	27	156	102	81	146	105	140	13	4	PG-11
EMA 750-4	A	404	210	230	205	30	200	97	106	185	120	170	17	4	PG-13,5
EMA 900-4	A	404	210	230	205	30	200	127	106	185	120	170	17	4	PG-13,5
EMA 1150-4	A	463	210	230	205	30	200	127	106	185	120	170	17	4	PG-13,5
EMA 1450-4	A	549	230	252	235	30	225	152	120	208	140	190	17	4	PG-16
EMA 1800-4	A	549	230	252	235	30	225	152	120	208	140	190	17	4	PG-16
EMA 2050-4	A	549	230	252	235	30	225	152	120	208	140	190	17	4	PG-16
EMA 2350-4	A	629	230	252	235	30	225	193	120	208	140	190	17	4	PG-16
EMA 2400-4	A	528	280	282	268	35	260	126	137	240	155	225	22	4	PG-16
EMA 3200-4	A	608	280	282	268	35	260	166	137	240	155	225	22	4	PG-16
EMA 4000-4	A	617	310	323	317	38	300	146	160	280	155	255	23,5	4	PG-21
EMA 4500-4	A	617	310	323	317	38	300	146	160	280	155	255	23,5	4	PG-21
EMA 5000-4	A	618	340	363	350	40	335	129	172	317	180	280	26	4	PG-21
EMA 5700-4	A	618	340	363	350	40	335	129	172	317	180	280	26	4	PG-21
EMA 5750-4	A	850	390	385	380	42	380	230	195	360	200	320	28	4	PG-21
EMA 6500-4	A	660	390	385	380	42	380	135	195	360	200	320	28	4	PG-21
EMA 8200-4	A	700	390	385	380	42	380	135	195	360	200	320	28	4	PG-21
EMA 8600-4	B	847	460	457	496	45	420	170	218	400	125	380	39	6	PG-29
EMA 10200-4	B	847	460	457	496	45	420	170	218	400	125	380	39	6	PG-29
EMA 11500-4	B	847	460	457	496	45	420	170	218	400	125	380	39	6	PG-29

Tip	Poz	A	B	C	D	E	F	G	H	K	L	M	N	P	Kablo Girişi
EMA 40-4	A	260	125	160	120	21	117	65	61	102	61-75	106	9	4	PG-11
EMA 70-4	A	260	125	160	120	21	117	65	61	102	61-75	106	9	4	PG-11
EMA 100-4	A	260	125	160	120	21	117	65	61	102	61-75	106	9	4	PG-11
EMA 200-4	A	300	154	180	142	25	144	76	75	129	90	125	13	4	PG-11
EMA 250-4	A	300	154	180	142	25	144	76	75	129	90	125	13	4	PG-11
EMA 450-4	A	360	170	198	150	27	156	102	81	146	105	140	13	4	PG-11
EMA 500-4	A	360	170	198	150	27	156	102	81	146	105	140	13	4	PG-11